



650 N 中耕管理機 CULTIVATOR

使用保養說明書

Operation and Maintenance Manual

使用前請務必詳細閱讀本說明書

2024.11 年製

◆目錄 Table Of Contents	1
一、各部位名稱 Machine Structure	2
二、引擎啟動前確認 Check Before Engine Starts	3
三、操作使用說明影片 Operation Guide Video	3
四、潤滑/保養/調整 Lubrication/ Maintenance /Adjustment	3~4
五、安全注意事項 Safety Remarks	4~5
六、長期放置 Long Term Storage	5
七、隨機配件清單 Accessories	5
八、產品保固卡 Accessories-Warranty Card	6~7

一、各部位名稱 Machine Structure

編號 / NO	零件名稱 / Parts Name
1	加油線 Accelerating Wire
2	調整阻力棒桿 Clutch Handle Lever Grip
3	注油孔 Oil Filler Cap
4	耕耘刀 Tilling Blade
5	變速箱 Gear Box
6	引擎加油孔 Engine Oil Fill Cap



編號 / NO	零件名稱 / Parts Name
7	汽油引擎 Gasoline Engine
8	卸油孔 Oil Drain
9	皮帶覆蓋 Belt Cover
10	變速桿 Gear Lever
11	阻力棒 Clutch Handle Grip
12	名牌斜臂 Handle Base
13	離合器線 Clutch Wire
14	把手調整高低螺絲 Handle Adjustment Knob Bolt
15	CE 離合器把手 Clutch Handle

二、引擎啟動前確認 Check before engine starts

1. 各部位螺絲，螺帽等有無鬆動現象。
Check bolts and nuts of all parts to avoid any looseness.
2. 把手架各個手柄有無鬆動現象。
Check the handle bracket to avoid any looseness.
3. 各潤滑部位是否依照指示適時加入潤滑油。
Follow the direction, make sure the lubrication oil is already added in all lubrication parts.
4. 機械稍作運轉移動，檢查有無異常的聲音及異常發熱的地方。
Start the engine and moving the machine to check if there is any abnormal noise and heat.
5. 作業刀具之刀口或左右邊必需配合軸心轉向否則無法作業。
The edge or left and right sides of the blade should be coordinated with the rotational direction of the axle, otherwise will not be able to operate.

三、操作使用說明影片 Operation Guide Video



English 英文



Chinese 中文

四、潤滑/保養/調整 Lubrication/ Maintenance /Adjustment

1. 引擎 Engine : #30 機油 engine oil
 - (1) 引擎潤滑油更換時機：第 1 次使用 15 小時潤滑油更換，之後每操作 80 個小時更換 1 次。
Engine oil periodic change schedule : Initial change for the first 15 hrs operation, after each 80 hrs operation, the engine oil must be changed.
 - (2) 更換方式：添加時機身放平，放鬆洩油孔螺絲使油完全漏掉後鎖上螺絲，由注油孔注入機油，依油尺刻度為標準。
How to change: Place the cultivator on a level surface and hold it in an upright position. Loose the oil drain screw to drain all the oil. Add the new oil from the oil filler cap, and then check the suitable oil level on the dipstick.
2. 空氣濾清器(油式)內加注#30 機油至油杯標示線止，勿注入中心圓孔內，進入汽缸。注意：潤滑油更換時空氣濾清器須一同清洗換油。
Air cleaner (oil type): #30 engine oil. Add the oil to the oil cup level mark. Do not put the oil into the center hole(cylinder) 。Caution: When changing the engine oil, Air cleaner should be clean and oil change.
3. 行耕部(變速箱) Run body and tillage part (Transmission) : #90 機油 engine oil.
 - (1) 行耕部潤滑油更換時機 :第 1 次使用 15 小時潤滑油更換，之後每操作 160 個小時更換 1 次。
Engine oil periodic change schedule for Run body and tillage part : Initial change for the first 15 hrs operation, after each 160 hrs operation, the engine oil must be changed.
 - (2) 更換方式：添加時機身放平，放鬆行耕部本體之洩油孔螺絲使油完全漏掉後鎖上螺絲，由注油孔螺絲注入至探油窗 6 分滿位置即可。
How to change: Place the cultivator on a level surface and hold it in an upright position. Loose the oil drain screw on the Run body and tillage part to drain all the oil. Add the new oil from the oil filer cap, and then check the suitable oil level on the oil window to 60 percent full.

4. 離合器調整 Clutch adjusting arm

- (1) 當離合器柄切入時，使張力輪往上壓皮帶下方使皮帶壓緊產生傳動作用，如圖示(A-3)引擎皮帶兩端皮帶呈平行狀態為最適當。When the handle of the clutch is inserted, the tension wheel presses the bottom of the belt upward. The belt is pressed tight and produces transmission action. As shown in Figure (A-3). The two end belts of the engine belt should be level for optimal operation.
- (2) 當離合器柄放鬆時張力輪往下產生離的作用使傳動皮帶微接觸於皮帶調整滑片上，圖 A-3
When loosening the clutch handle, the tension produces downward separation action. It causes the transmission belts slightly contacting the plate belt hook. Figure A-3
- (3) 離合器導索之間隙必須預留約 8~15mm 避免張力輪無法壓緊皮帶產生皮帶打滑磨損，圖 A-4
Reserve 8~15mm for the gap of the leading rope of the clutch. This is to avoid tension wheel from being unable to tighten the belt and lead to belt sliding and wear. Figure A-4

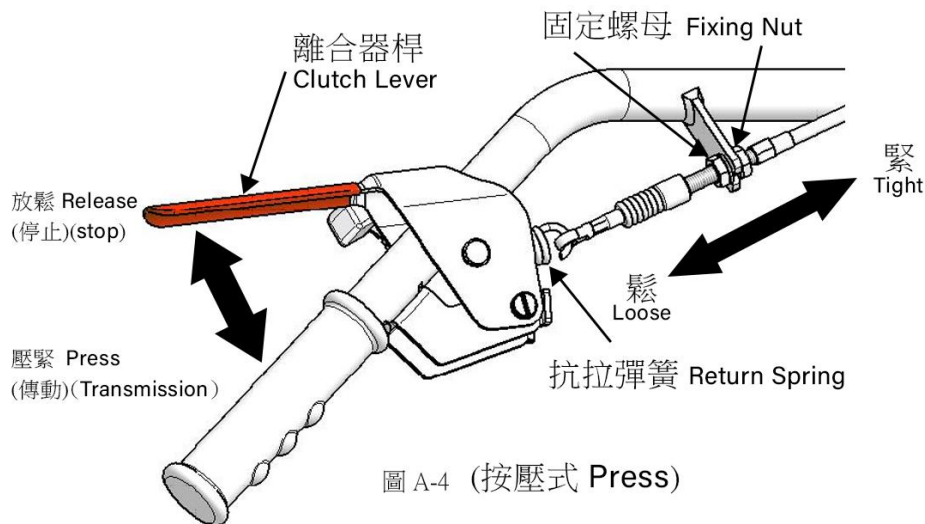
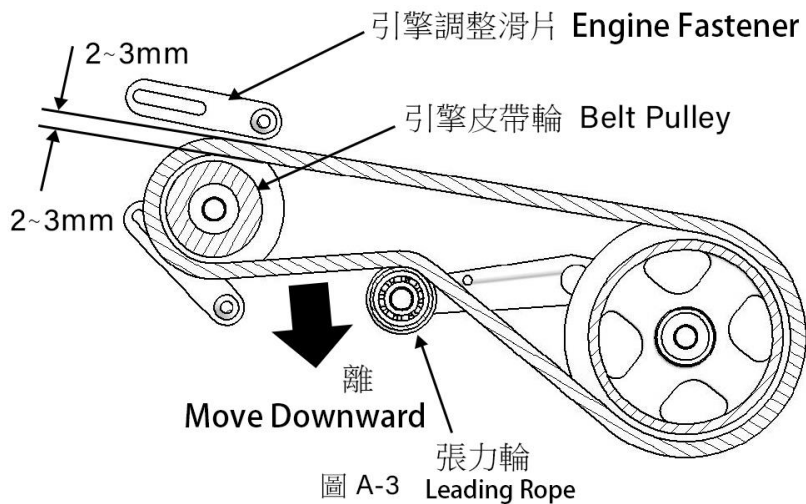

五、安全注意事項 Safety Remarks

1. 作業前機器檢查 Machine check before operation
檢查機器時，必須在引擎完全停止的安全狀況下檢查。
When checking the machine, the engine shall be stop complete for safety condition.
2. 作業刀具的各部螺絲，螺帽必須確實鎖緊。
Bolts and nuts for all parts of the operation blade shall be tightened..
3. 作業中的安全事項 Safety notes during operation

- (1) 每次作業前檢查離合器功效，離合器效果不佳時可調整導索或通知保修人員。
Check the performance of the clutch before operation. If the clutch performance is poor, adjust the leading rope or call the mechanic.
- (2) 操作者作業時，身體重心必須保持穩固。
When the operator is operating the machine, the center gravity of the operator shall be hold steady.
- (3) 操作者不可於刀具前進之前方操控作業，以確保人身安全(即嚴禁操作者以後退行走方式操控作業)若須使用後退檔時，先暫時停止刀具運轉，並降低油門觀察後方及將障礙排除，確保後方安全無慮之後，再以低速檔小心倒退(非必要時，勿使用後退檔)。
The operator should not operate the machine in front of the forward direction of the rotary blade to protect the operator's safety (Strictly prohibit the operator using the reverse method to operate the machine.) If the reverse operation is required, first stop the rotary blade and decelerate and observe the rear situation and remove any obstacles. Make sure that the rear is safe, then reverse the gear in low speed mode with extra care (Unless it is necessary, do not use the reverse operation.)
- (4) 引擎運轉中若遇有故障或障礙需排除時，必須將引擎熄火再排除障礙，以確保人身安全。
During the engine operation, if there are any breakdown or obstacles need to remove, should turn off the engine before the trouble shooting to protect the operator's safety
- (5) 引擎運轉中勿碰觸排氣筒，皮帶輪及任何轉動部位。
During the engine operation, do not touch exhaust pipe, belt wheel and any other rotary parts.

六、長期放置 Long term storage

1. 各部清洗乾淨後，檢查各部位螺絲是否有鬆動、漏油、損壞。
After clean all parts, to check if there is any looseness or oil leak or damages for all bolts of each part.
本機易生銹部分，在使用後，清洗乾淨並必須塗抹防銹油或噴漆以防生銹。
For the easily rusted parts of the machine: after using the machine, should wash clean and daub with the antirust oil or spray paint to prevent rusting .
將油箱燃料漏乾並將引擎發動至自行熄火為止(化油器及油管內均無燃料)再將火星塞口處入機油於汽缸內，爾後拉引擎起動拉柄，使活塞反覆運動十數次，再把火星塞鎖緊，並使活塞於汽缸內呈壓縮狀態。
Drain away the fuel from the fuel tank and switch on the engine until the engine stop (no fuel in carburetor and oil pipe) and infuse the engine oil into the cylinder from the spark plug cap and then pull the engine start handle to move the piston back and forth for more than ten times, then lock the spark plug to make the piston stay in compression condition in the cylinder.

七、隨機配件清單 Accessories

1. 八聯耕耘刀 (一組) 8- Rotary Tillage Blade (1 set)
2. 工具袋 (一只) Tool Bag (1 bag)



NICHINO®

產品保固卡

Warranty Card

◎產品保固說明 Product Warranty

- 一、憑此保固卡，得享有本公司及經銷商所提供自購買日起正常使用下一年內保固維修服務。By this warranty card,can have warranty maintenance services from our company or dealers since the purchase date of the normal use within one year.
- 二、如有下列情況之一者，雖在保固期間內恕不免費更換零件或維修服務: If any of the following circumstances,although during the warranty period without a free replacement parts or mainenance services:
 - (1)未按正確使用說明指示實施定期檢查保養及操作，或因為人為疏失以致損壞者
If not under the proper use of indicates that the implementation of regular inspection and maintenance and operation,or because of human error resulting in damage.
 - (2)使用時超過規定工作限度(例如:使用超出機種負載作業刀具，碰撞障礙物或石頭導致損壞等)。Use exceed the prescribed limits.(for example:to use over machine load operating tool,collision obstructions or stones cause damage,etc.)
 - (3)擅自拆裝或改裝而導致損壞者。Unauthorized disassembly or modification of a result of damage.
 - (4)消耗品:刀具、皮帶...等。Consumables:blades、belt etc.
 - (5)使用非本公司之原廠零件、耗材及使用變質或劣質潤滑油導致損壞。Use of non-original brand parts,consumables or use of deterioration or poor quality lubricants cause damage.
 - (6)由於天災地變及其他人力不能抗拒因素所發生的故障(如颱風、地震、水災等)
Irresistible nature disasters (such as typhoons、earthquakes、floods、etc.).

【受理保固的方法 Accepted warranty】

-
- ◎當需要保固修理時，請以整機勿自行拆卸並攜帶產品保固卡到購買本產品的經銷商申請修理，未攜帶保固卡時不給予保固修理。
 - ◎When need warranty repairs,bring the complete machine and not to disassemble , and carry a warranty card to apply for repair to the dealer which you bought the product.Will not provise warranty repair service by seeing warranty card.

一年保固、終身服務

Year warranty and lifetime service



產品保固卡



Warranty Card

承蒙惠顧，不勝感激，為確保您的權益，請妥善保存此卡 Please reserve this card for warranty purpose.

客戶姓名 Name		聯絡電話 Tel	
聯絡地址 Add			

產品資料 Product information

廠牌名稱 Brand	日農牌 NICHINO
機具名稱 Machine Name	中耕管理機 Cultivator
型號 Model No.	
引擎馬力 Horse Power	
使用燃料 Use Fuel	
引擎號碼 Engine No.	
本機號碼 Chasis NO.	

購買日期Purchase date:

年Y 月M 日D

經銷商蓋章處
Dealer Shop Seal

(未蓋經銷商店章無效)
(Without seal this card is invalid)

注意事項:

- 為確保您的權益，請詳細填寫此卡之資料，以作為購買之憑據，領請填妥購買日期，校對機身產品序號加LINE回傳或傳真至本公司，始享有購買日期起本公司一年之保固服務;恕未能出示保固卡或內容記載不實、塗改；毀損不清，以致無法辨識時，恕不免費保固。To ensure your rights, please fill this card as the proof of purchase, also please fill the purchase date. Proofread the serial number on fuselage, then send it by LINE or fax to IE-IE (Nichino) company, to have one year warranty service from the purchase date.If the warranty card is missing or the content is incorrect, altered, damaged or unclear, which can not be identified, the warranty will be invalid.
- 以上個人資料，僅供售後服務使用，不作其他用途使用。Above information is only for after-sales service purpose.
- 如果您購買的日農產品萬一出現品質不良現象，本公司將依據保固卡所述事項予以保障(相關「產品保固說明」請見背面) If the product you purchased is of poor quality, our company will still provide protection according to this warranty (Please see the previous 「Product Warranty」).
- 本保證需永久保存(即使保固日期已過)，如有損失，破損，恕不補發。The guarantee need to permanently save (even if the warranty has expired),for any loss,damage,will not be reissued.
- 本保固書僅提供本產品保證，不得作法律上任何其他用途。This warranty is only provided to ensure this product,it is not for any other purpose in the legal.

宜益股份有限公司
IE-IE CORPORATION

<http://www.ietw.com.tw>

電話Tel:+886-2-2622-3877

傳真Fax:+886-2-2625-6867

地址:新北市淡水區忠山里奎柔山路419號

ADD:NO.419,Kuiroushan Rd.,Tamsui Dist.,New Taipei City,Taiwan.(R.O.C)





宜益股份有限公司
IE-IE CORPORATION

官網 Official website

Facebook



英文 English



中文 Chinese



英文 English



中文 Chinese